



**PERFORADORA  
NEUMÁTICA  
»YT29A**



**MARAGA**

## Scope of application

YT29A is a heavy-duty pusher leg Rock Drill featuring high efficiency and low air consumption. It is primarily designed for drilling in mines, hydropower stations, and road construction projects. It is also a new product suitable for tunneling and other stone works in mining and metallurgical industry.

YT29A is suitable for both horizontal and upward anchor holes in medium-hard and hard rocks (100–350 MPa). The hole diameter range is from 32 mm to 45 mm with depths up to 5 meters. The Rock Drill is equipped with lubricator FY250. YT29A is intended to be used together with pusher leg FT160A, FT160B, FT160C or FT170 for different tunneling and work conditions. It is also designed for dry drilling or wet drilling mounted on rigs.

## Specification

Pneumatic rock drill YT29A		
Weight	27	kg
Dimension (L x W x H)	659x248x205	mm
Cylinder diameter	82	mm
Piston stroke	60	mm
Working pressure	3,5–5	bar(e)
Impact energy (at 5 bar(e))	≤70	J
Air consumption (at 5 bar(e))	≥65	J
Impact frequency (at 5 bar(e))	≥37	Hz
Water pressure	working pressure -1	bar(e)
Air hose inner diameter	25	mm
Water hose inner diameter	13	mm
Drilling diameter	32-45	mm
Max Drilling depth	5	m
Working temperature	-30 to +45	°C
Shank size	H22x108±1	mm
Noise level	≤127	dB(A)
Lubricator FY250		
Weight	1.2	kg
Capacity	0.25	litre

## Safety instructions

To reduce the risk of serious injury or death to yourself or others, carefully read through this instruction booklet before putting the rock drill to use. Always follow the instructions given.

- Always wear a safety helmet, goggles and ear protectors with CE mark during drilling. Any local regulations that exist must also be observed.
- When drilling in certain minerals, there is a risk of spark generation. Before starting work, check that the machine is approved (in accordance with local regulations) for work under such conditions.
- Always take great care when using the machine. The working tool is subjected to heavy loading and can break, with a risk of injury to personnel.
- Check that the hoses used are of the right quality, and that all hose connections are in good condition and properly tightened.
- Before starting work on any of the systems, make sure that the air and water systems are without pressure.
- Make sure that there are no concealed wires or other sources of electricity. Never drill near any electric wires or other sources of electricity.

## Operation

### Using the rock drill for the first time

When the rock drill arrives from the factory, the inside of the tool is coated with heavy oil to prevent corrosion.

After unpacking and installing the tool, pour a small amount of lubrication oil into the air connection and operate the tool on partial throttle to clean the interior. Follow this immediately with a liberal amount of air tool oil.

The rock drill and pusher leg are lubricated with oil mixed with compressed air, which is taken to the parts that need continuous lubrication. Oil is metered into the compressed air using the FY250 lubricator connected to the air line.

### Preparations before starting

1. Check the drilling equipment
  - Check that all of the drilling equipment is in good working order.
  - Check that the impact surface of the working tool shank is flat, with no signs of wear.
  - Make sure that the air inlet and exhaust ports are free from obstructions.
  - Check that the flushing holes in the working tool and drill bit are not blocked, and that the flushing air/water flows through without obstruction.
  - Ensure that the fittings are tight and leak-proof.



### WARNING

Always check for damaged or loose hoses and fittings before operation. Whipping hoses can cause serious injury.

## 2. Blow out the air hose

Every day before using the drill, blow out the air hose to clear it from accumulated dirt and moisture.

## 3. Fill the lubricator with oil

Check the lubrication oil level, fill the lubricator if necessary.

**Note!** Check that the chuck and working tool shank are always covered by a film of oil.

**Note!** Always use a recommended lubricant. Operation without lubrication is not allowed.

Lubricant	Recommendation	
Air tool oil	Use a mineral-based air tool oil	
	Ambient temperature °C	Viscosity grade (ISO 3448)
	-30 to 0	ISO VG 32-68
	-10 to +20	ISO VG 68-100
	+10 to +50	ISO VG 100-150

## 4. Air/water pressure and hose dimensions

### Air pressure

Ensure that the compressor can deliver the required air pressure of 5 bar at the tool.

- High pressure (>6.3 bar) causes rough operation and damage.
- Low pressure (<4 bar) results in a slow drilling speed.

### Water pressure

Make sure that the water pressure is set to around 3 bar.

**Note!** Maximum water pressure is 1 bar less than the working pressure. For example if the air pressure is 5 bar, the water pressure must be below 4 bar to prevent water entering the impact mechanism.

**Note!** Dry drilling is strictly prohibited. Operation without air- and water tubes is not allowed as it will result in poor drilling performance.

### Hose dimensions

The air hose diameter must be no less than 25mm. Inner diameter of connection nipple and hose must be no less than 19mm. The ideal overall air hose length is less than 15m.

## Fitting and removing the tool

### Before fitting the working tool

- Check that the tool shank is of the correct size and length for the chuck used.
- The shank must be clean and the tool must be in good condition.
- The suitable quenching hardness of the shank is HRC48-53. Harder end face will cause piston damaged and breakage of the end face of the piston. If the shank face is too soft, it will be easily deformed by the piston, which will result in difficulty in removing the working tool.
- Shank end face shall be flat and perpendicular to the axis.
- Remove sharp edges from the shank's end face. Rough shank surface will cause premature piston failure.
- Inspect the bits: Dull bits will slow down the drilling speed and overstrain the drill mechanism. When changing bits make sure that the new bit is the correct size to follow your previous bore.
- Before drilling check that the flushing hole in the working tool is not blocked.

## Fitting the working tool

1. Push the retainer outwards in the direction of the arrow (see picture below), until the front portion of the retainer is able to accommodate the working tool collar.
2. Insert the drill in the chuck.
3. When the drill bottoms, push back the retainer to lock it.

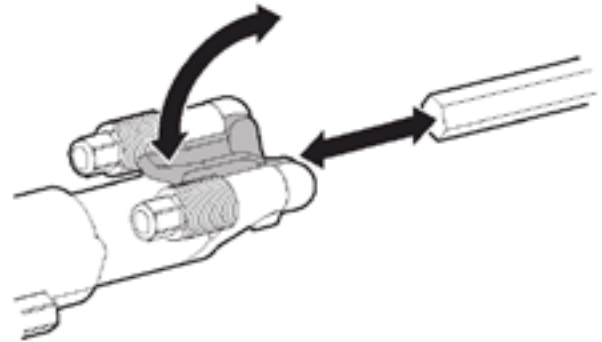

## Removing the working tool

1. Push the retainer outwards in the direction of the arrow until the working tool collar disengages from the front of the retainer.
2. Pull the working tool out.
3. Push back the retainer.

## Attaching the pusher leg to the rock drill

- Mount the pusher leg (1), lock sleeve (2), rubber pad (3), washer (4) and locking nut (5) in the order shown in the picture below.
- Turn the locking nut clockwise with a wrench until you hear a "click".

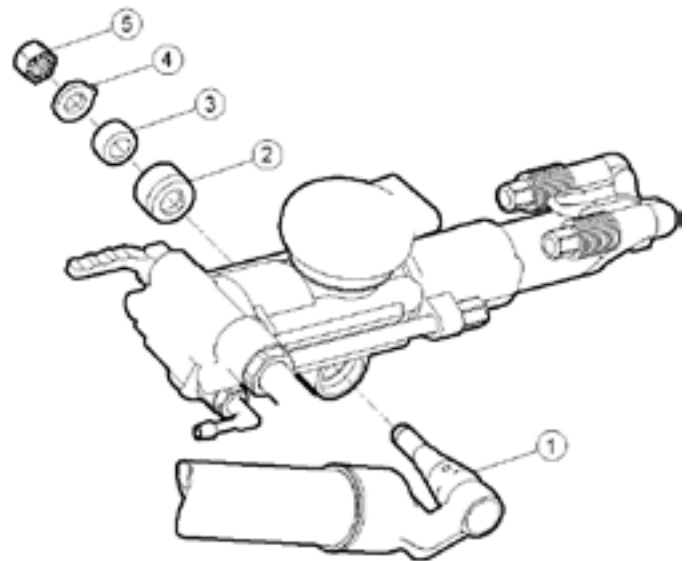

## Controls

### Throttle lever

The rock drill is equipped with a throttle lever for regulating both the compressed air to the percussion mechanism and the flushing water.

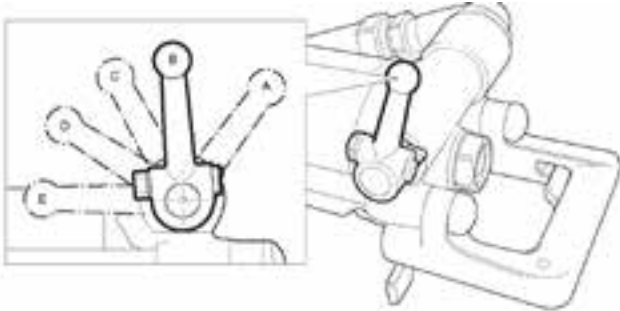

- A. Extra blowing, water flushing off, impact and rotation off.
- B. Stop position, air and water off
- C. Low throttle, air to pusher leg, water flushing
- D. Medium throttle
- E. Full throttle

### Feed control

Adjust the feed force by means of the feed control lever as follows:

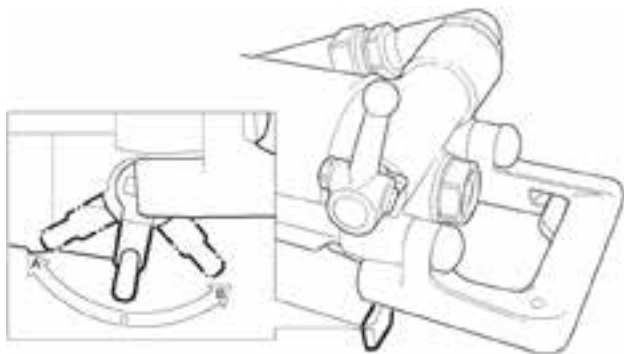

- A. Pushing the lever in this direction will increase feed force.
- B. Pulling the lever in this direction will decrease feed force

### Trigger

When the trigger (A) is pushed in, the feed force stops abruptly and the setting on the feed control lever is overridden. The piston rod in the pusher leg retracts automatically. This function is used for example to adjust the height of the rock drill, when rigging up the pusher leg, or when there is a tendency to jam. When the trigger is released, the feed control setting is activated again.

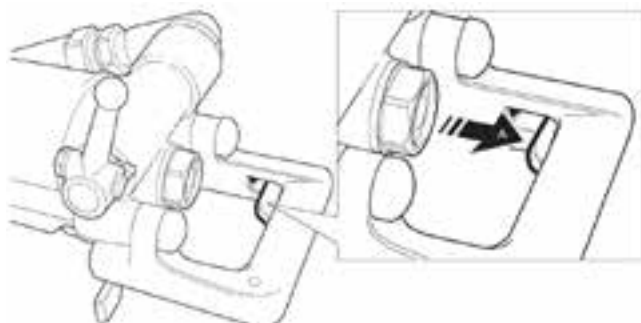

## Oil regulating valve

Oil dosing is controlled by means of a screwdriver.

Check that sufficient lubrication is obtained by putting your hand in front of the exhaust port while adjusting the regulating valve. If the hand is covered by a thin film of oil after a few seconds, the lubricator has been correctly adjusted.

The amount of oil going into the rock drill increases when turning the valve counter clockwise, and it decreases when turning the valve clockwise. Oil consumption is 2.5–6 ml/minute.

**Note!** Tighten the nut after regulation.

**Note!** Too much oil will have negative effects on the operation whilst too little will result in damage to parts as the temperature rises during operation.

## Drilling

### Starting the rock drill

1. Open the main valve for compressed air.
2. Open the cock for the flushing water.
3. Adjust the feed control lever to give a suitable feed force for collaring the hole.
4. Align the rock drill so that the working tool touches the desired collaring point.
5. Move the throttle lever forward a little, which will start water flushing, percussion and rotation.
6. Collar the hole with reduced feed force.
7. Move the throttle lever fully forward once the working tool has gained a secure footing in the rock.
8. Adjust the feed force by means of the control lever so that the maximum penetration rate is obtained.

**Note!** Do not bend the working tool as this will increase wear of the shank bushing and piston. Furthermore, it can also affect drilling efficiency and increase the risk of working tool breakage.

### Stopping the rock drill

Pull the throttle lever backwards, which will stop percussion, rotation and flushing water.

### Re-positioning the pusher leg

1. Switch off the rock-drill percussion and flushing by means of the throttle lever.
2. Press the trigger, whereupon the piston rod is pulled back into the pusher-leg cylinder automatically.
3. Re-position the pusher leg.
4. Release the trigger, whereupon the piston rod will move outwards again.
5. Move the throttle lever forward into the working position.

**Note!** The feed control lever does not need to be touched throughout this operation.

## Blow-cleaning the drill hole

### CAUTION

Move to the side and cover your eyes before starting to blow-clean the drill hole. When blow-cleaning, particles and dirty flushing water can emerge at speed from the drill hole.

- Always wear impact resistant eye protection with side protection to avoid injury.
- Make sure that no co-workers are in range when blow-cleaning.

If powerful blow-cleaning of the drill hole is required, turn the throttle lever fully backwards beyond the stop position for extra blowing, whereupon the rock drill stops. This can be done during drilling. When the drill hole is clean, turn the throttle lever forwards again to re-start the rock drill.

When you have finished drilling

Run the rock drill at medium speed when retracting the working tool from the drilled hole.

Lay down the rock drill on a stone, wooden plank or similar object, so as to prevent drill cuttings and other foreign matter from entering the chuck.

Turn off the water pressure before the air pressure. Run the rock drill for a few seconds to clean out water and moisture after the water has been shut off.

## Maintenance

Regular maintenance is a prerequisite for machine safety. Replace damaged and worn components in good time. For a major service to the machine, contact your nearest authorized workshop.

Check the machine and tools for wear and damage at regular intervals. Do not use very worn or damaged tools.

When cleaning mechanical parts with a solvent, make sure that you comply with current health and safety regulations and ensure that there is sufficient ventilation.

Daily maintenance, regular checking of wearing parts and carrying out repairs in good time prevents breakdowns and increases the service life of the machine.

- Always oil the rock drill and pusher leg well, before you put them into storage.
- Store in a clean and dry place.
- Make sure that no foreign matter enters the machine.
- Protect the chuck using a wooden plug or a clean piece of cotton waste.
- Always hose down and wipe clean the rock drill and pusher leg after use.
- In the case of long-term storage, pour a quantity of oil directly into the rock-drill's air intake and then turn on the air briefly. This will protect the machine from corrosion.

### Selection of spare parts

This machine is a heavy-duty rock drill; there are strict requirements on selecting spare parts. Use only genuine parts for replacement, to ensure stable performance. Do not use pattern parts, which not only have a short working life but also cause consequential damage to other parts, due to differing measurements and methods of manufacturing.

### Once a shift (after 8 hours of operation)

Check the wear in the chuck bushing. If the wear limit has been exceeded, the working tool shank will wear more quickly, or

become deformed. This will lead to stoppages and increased working tool consumption.

- Check the tightness of the side-bolt nuts. The tightening torque shall be 80 Nm.
- Check the rock drill's connection to the pusher leg.
- Check the hoses, couplings and controls for leakage and damage.
- Check that the rock drill and pusher leg are receiving enough lubrication. Fill the lubricator as necessary.
- Drain the water separator.
- Check the air and water pressure. Make sure that the water pressure is at least 1 bar lower than the air pressure.

### Once a week (after 40 hours of operation)

- Carry out a basic check of all functions of the drilling equipment.

### Once a month (after 200 hours of operation)

- Send the rock drill to a workshop for inspection. The local operating conditions will determine whether or not this is a suitable interval for overhauling the drill.
- Dismantle and clean the lubricator.
- Clean out the water separator.

## Measures to prevent freezing

In low ambient temperatures, ice can form in the machine. This can be avoided if the water in the compressed air is removed. This can be done by equipping the air lines with water separators and drainage points for water condensate.

If the rock drill ices up, it must not be heated to melt the ice. Let the ice thaw at room temperature.

**Note!** Do not pour methylated spirits or similar substances into the rock drill, as they will interfere with the lubrication and lead to increased wear.

## Scrapping and waste disposal

Used and worn-out machines must be disposed of in such a way that as much of the material as possible can be recycled and the impact on the environment is kept to a minimum.

# Trouble shooting

Problem	Cause	Solution
Decreased penetration rate	Air leakage in hoses, couplings	Change packings, and where required, change parts in the throttle valve.
	Shank sleeve	Check the shank sleeve for excessive wear. Replace if necessary
	Air leakage due to worn piston/cylinder	Replace the piston and/or cylinder
	Air leakage due to worn guide sleeve/pilot guide	Change the worn part
Insufficient feed force	Piston rod seal (in pusher leg) worn or deformed	Change the seal
	O-rings on pusher leg coupling worn or deformed	Change the o-rings
Poor rotation	Splines of the rifle nut worn	Replace the rifle nut if the splines are worn
	Splines of the rifle bar worn down	Replace the rifle bar when needed
	Splines on the piston worn down	Replace the piston when needed
	The toothing in the ratchet housing is worn out	Replace the ratchet housing if the tooth housing is so worn that the pawls have difficulty catching
	The toothing in the ratchet wheel is worn out	Replace the ratchet wheel if the toothing is so worn that the pawls have difficulty catching
	Chuck nut worn out	Replace the chuck nut if the splines have been worn to 1/2 of the spline width
	Pawls worn	Replace all pawls, all pawl springs and all pawl pins
Uneven running	Piston has seized in the guide sleeve or the piston guide	Replace the guide sleeve/piston guide. If required, polish the piston. Check the piston for heat damage such as blue colouring and/or fissures. If it is damaged in this way, replace the piston as well
	Dirty or damaged main valve. Caused by impurities or foreign matter entering the drill with the compressed air	Clean and polish the valve so that it seals against the corresponding cylindrical and plane sealing surfaces. If this is not possible because the defects are too serious, the valve must be replaced
	Freezing. Caused by leakage in the flushing system or by excess water in the compressed air or by excessive water pressure	Check the flushing tubes and seals and the water pressure. Drain water from the compressed air system. If the problem continues, fit a water separator in the airline system
Uneven running (continued)	The side bolts are unevenly or insufficiently tightened. Can cause the various parts to lose their alignment, resulting in the seizure of the movable parts. Abnormal strains on the side bolt may result in fracture at the threads	Check and repair any damage to the contact points and tighten the bolts with the correct tightening torque
The drill gets hot	Lack of oil	Add oil and check that it runs through. It is not sufficient that there is oil in the exhaust air. There must also be an oil coating on the shank of the working tool
Freezing	High level of humidity in the compressed air	Use water traps
	Water pressure higher than the air pressure	Lower the water pressure
Water pipe breakage	Misalignment of the shank	Change working tool or shank sleeve or both
	Damaged flushing hole in the shank	Change working tool
Chipping of the piston tip	Misalignment of the shank	Change the working tool or shank sleeve or both
	Excessive wear of the piston tip	Change piston
Spline breakage	Lack of lubrication	Lower the water pressure if it is the same as or greater than the air pressure
		Increase lubrication or change oil
	Dirt intrusion (specially when drilling upwards)	Increase service intervals
Piston breakage	Lack of lubrication	Lower the water pressure if it is the same as or greater than the air pressure
		Increase lubrication or change oil
	Uneven tension in the side bolts	Tighten the bolts correctly
	Worn guide sleeve/piston guide (can be confirmed by the cushion test)	Change the worn part
Side bolt breakage	Uneven tension on the bolts	Tighten the bolts correctly

# Spare parts

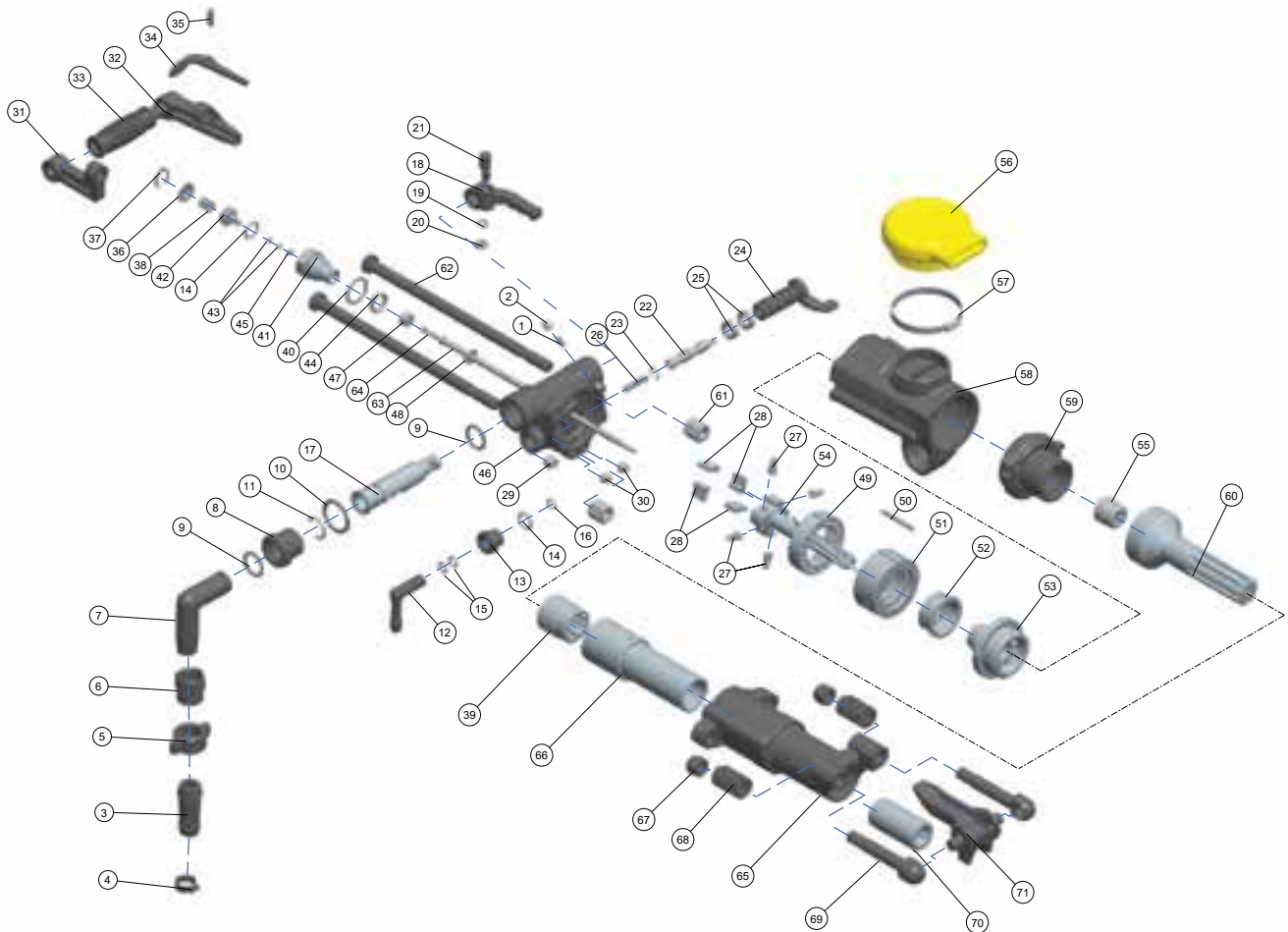

Ref.	Part	Qty	Prod. No.	Product code
1	Spring	1	96000179	9605-1-3312310169
2	Pin	1	96000180	9605-1-3312310170
3	Conical pipe connector	1	96000186	9605-1-3312310176
4	Hoop	1	96000540	9605-1-3312310723
5	Wing nut	1	96000185	9605-1-3312310175
6	Pipe connector	1	96000187	9605-1-3312310177
7	Air pipe swivel	1	96000825	9600-1-3312310022
8	Air pipe nut	1	96000823	9600-1-3312310020
9	O-ring	2	96000486	9605-1-3312310633
10	Pad	1	96000174	9605-1-3312310164
11	Retaining ring	1	96000182	9605-1-3312310172
12	Water pipe connector	1	96000154	9603-1-3312310143
13	Water pipe nut	1	96000155	9603-1-3312310144
14	O-ring	2	96000482	9605-1-3312310627
15	O-ring	2	96000499	9605-1-3312310667
16	Water pipe connector retaining ring	1	96000156	9603-1-3312310145
17	Control valve	1	96000646	9605-1-3312311868
18	Control handle	1	96000152	9603-1-3312310141

Ref.	Part	Qty	Prod. No.	Product code
19	Standard spring pad	1	96000534	9605-1-3312310716
20	Hex. thin nut	1	96000524	9605-1-3312310704
21	Fixing pin	1	96000177	9605-1-3312310167
22	Change valve	1	96000161	9603-1-3312310150
23	Retaining ring	1	96000160	9603-1-3312310149
24	Pressure regulating valve	1	96000119	9602-1-3312310101
25	Expansion	2	96000118	9602-1-3312310099
26	Spring	1	96000157	9603-1-3312310146
27	Conical spring	4	96000167	9605-1-3312310156
28	Ratchet pawl	4	96000166	9605-1-3312310155
29	Large seal sleeve	1	96000544	9605-1-3312310727
30	Seal sleeve	2	96000543	9605-1-3312310726
31	Right handle	1	96000163	9603-1-3312310152
32	Left handle	1	96000165	9603-1-3312310154
33	Shockproof handle	1	96000164	9603-1-3312310153
34	Trigger	1	96000162	9603-1-3312310151
35	Elastic pin	1	96000527	9605-1-3312310708
36	Spring cover	1	96000169	9605-1-3312310159

**Note! Tightening torque of side bolt nuts should be 80 Nm.**

# Spare parts

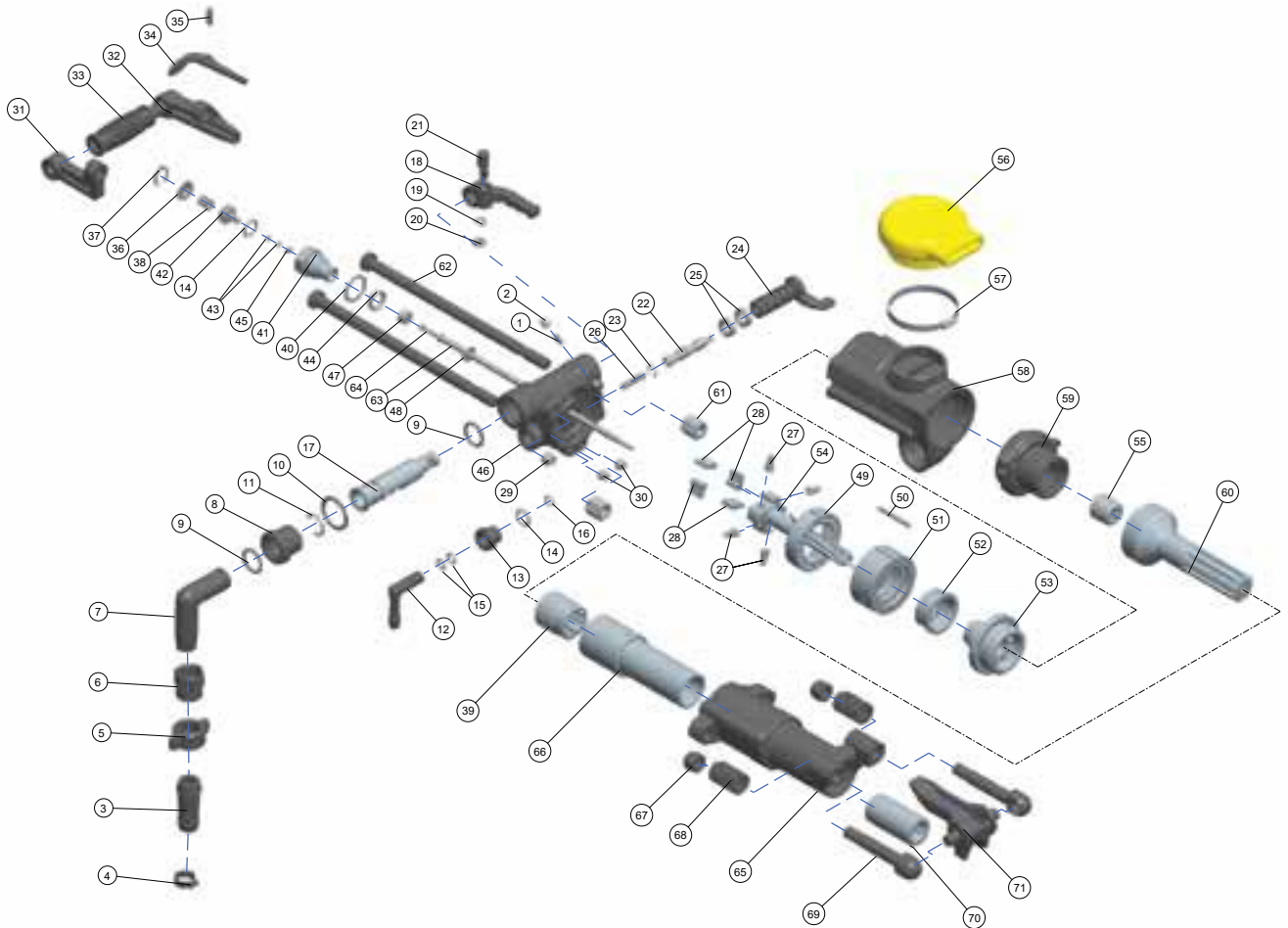

Ref.	Part	Qty	Prod. No.	Product code
37	Steel retaining ring	1	96000183	9605-1-3312310173
38	Spring	1	96000170	9605-1-3312310160
39	Rotation nut	1	96000146	9603-1-3312310135
40	Pad	1	96000184	9605-1-3312310174
41	Water valve body	1	96000171	9605-1-3312310161
42	Water valve	1	96000173	9605-1-3312310163
43	O-ring	2	96000489	9605-1-3312310642
44	Seal	1	96000181	9605-1-3312310171
45	Rubber pad	1	96000175	9605-1-3312310165
46	Back head	1	96000091	9605-1-3312310050
47	Water tube bush	1	96000835	9601-1-3312310035
48	Air tube pad	1	96000176	9605-1-3312310166
49	Ratchet	1	96000092	9605-1-3312310051
50	Dowel pin	1	96000839	9601-1-3312310039
51	Valve chest	1	96000093	9605-1-3312310052
52	Valve	1	96000094	9605-1-3312310053
53	Valve sleeve	1	96000639	9605-1-3312311860
54	Rifle bar	1	96000640	9605-1-3312311861

Ref.	Part	Qty	Prod. No.	Product code
55	Rifle nut	1	96000095	9605-1-3312310056
56	Exhaust deflector	1	96000562	9605-1-3312311050
57	Hoop	1	96000542	9605-1-3312310725
58	Cylinder	1	96000641	9605-1-3312311862
59	Guide sleeve set	1	96000732	9605-1-3312312340
60	Piston	1	96000642	9605-1-3312311863
61	Hex. Thick nut	2	96000518	9605-1-3312310697
62	Side bolt	2	96000643	9605-1-3312311864
63	Air tube	1	96000644	9605-1-3312311865
64	Water tube	1	96000645	9605-1-3312311866
65	Front head	1	96000647	9605-1-3312311875
66	Rotation sleeve	1	96000648	9605-1-3312311876
67	Nonmetal hex. Locking nut	2	96000531	9605-1-3312310713
68	Steel retainer springs	2	96000818	9600-1-3312310013
69	Steel retainer bolt	2	96000634	9600-1-3312311820
70	Shank sleeve	1	96000168	9605-1-3312310157
71	Working tool retainer	1	96000635	9600-1-3312311821

**Note! Tightening torque of side bolt nuts should be 80 Nm.**





Importado por:



*Lima:* Las Balsas 232, Urb. San Juan Bautista - Chorrillos.

*Trujillo:* Calle 10 (Mz. C, Lt. 01); Urb. El Prisma - Trujillo.

*Arequipa:* Mz. I, Lt. 3; 2da. Etapa, Urb. Tahuaycani - Sachaca.

Teléfono: (+51) 01 - 254 4859

Celular: (+51) 970 020 018 / 950 003 100 / 981 440 200

Correo: [online@lenmex.pe](mailto:online@lenmex.pe) / [ventas@lenmex.pe](mailto:ventas@lenmex.pe)

[www.lenmex.pe](http://www.lenmex.pe)

